

SYSTEM 3000 Specifications

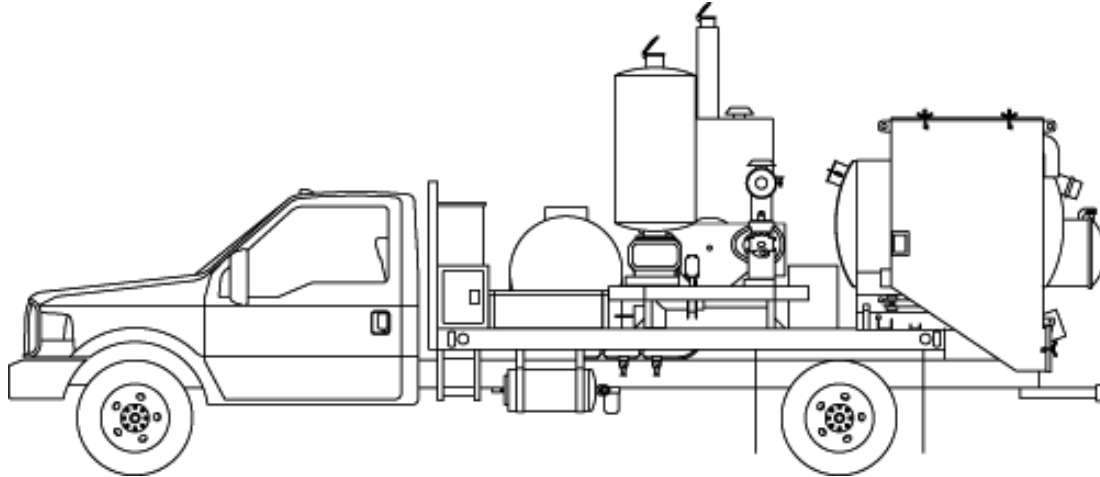

POWER SOURCE

Engine Type: 4-Cylinder Turbo Diesel
Model: John Deere 4045T 285
Power Rating: 99 hp
Fuel System: interconnected to truck system
Power Transfer: manual clutch, belt drive

DIMENSIONS and WEIGHTS

Length: 25' 3"
Width: 7' 4"
Height: 8' 6"
GVW: 19,500
Empty Wt. (lbs.): 16,100

OPERATIONAL DATA

Vacuum: 1000 cfm, 15" Hg, 4" hose
Compressor: 165 cfm @ 180 psi (Air Lance)
165 cfm @ 100 psi (Air Tools)
High-Pressure Water: 0–3000 psi @ 3 gpm
Low-Pressure Water: 0–1000 psi for clean-up

STANDARD EQUIPMENT

- Retractable Air Compressor Hose Reel
- Fiberglass Air Lance With Air-Tec™ Nozzle
- 1 Underbody Storage Box
- 2 Crossbody Storage Boxes
- L.E.D. Traffic Direction Board
- High-Pressure Water Wand
- Low-Pressure Water Wash-Down Wand
- Jackhammer Holster
- Winterizing Kit for Water System
- Vacuum Hose Rack
- Spare Nozzles
- Face Shields

TANK CAPACITIES

300-Gallon Spoils Tank with Hydraulic Hoist
100-Gallon Water Tank

OPERATOR CONTROL PANEL INSTRUMENTATION

Fully Supervised, Automatic Shut-Down

- Engine RPM
- Temperature
- Oil Pressure
- Vacuum
- Air Pressure

OPTIONAL EQUIPMENT [\(click here\)](#)

- Sandblast System
- Work Lights
- Barrel-top Soil Interceptor

HOSES

25' of 4" Smooth-Bore Plastic Vacuum Hose
33' of 4" Smooth-Bore Rubber Vacuum Hose
50' of 3/4" High-Pressure Air Hose for air lance
50' of 3/4" High-Pressure Air Hose for air tools
50' of 3/8" High-Pressure Water Hose